

Tri-State Autism Spectrum Disorder Webinar Series



This material was developed under a grant from the Colorado Department of Education. The content does not necessarily represent the policy of the U.S. Department of Education, and you should not assume endorsement by the Federal Government.

The content of this material was developed under an agreement from the Federal Department of Education to the Kansas Department of Education. However, those contents do not necessarily represent the policy of the Department of Education, and you should not assume endorsement by the Kansas Department of Education or the Federal Government. TASN Autism and Tertiary Behavior Supports does not discriminate on the basis of race, color, national origin, sex, disability, or age in its programs and activities. The following person has been designated to handle inquiries regarding the non-discrimination policies: Deputy Director, Keystone Learning Services, 500 E. Sunflower, Ozawie, KS 66070, [785-876-2214](tel:785-876-2214).

The contents of this power point presentation were developed under a grant from the Nebraska Department of Education, IDEA parts B and C from the U.S. Department of Education. However, this content does not necessarily represent the policy of the U.S. Department of Education and you should not assume endorsement by the Federal Government.

Tri-State 2018-2019 Webinar Series



Unstuck and On Target: Helping Students with Planning, Organization and Flexible Thinking

Laura Anthony, PhD

Associate Professor
Dept of Psychiatry, School of Medicine
U of CO Anschutz Medical Center
Pediatric Mental Health Institute
Children's Hospital of Colorado

Tri-State Webinar Fall 2018

**Conflict of Interest: Royalties on
Unstuck manuals**

Laura.Anthony@UCDenver.edu

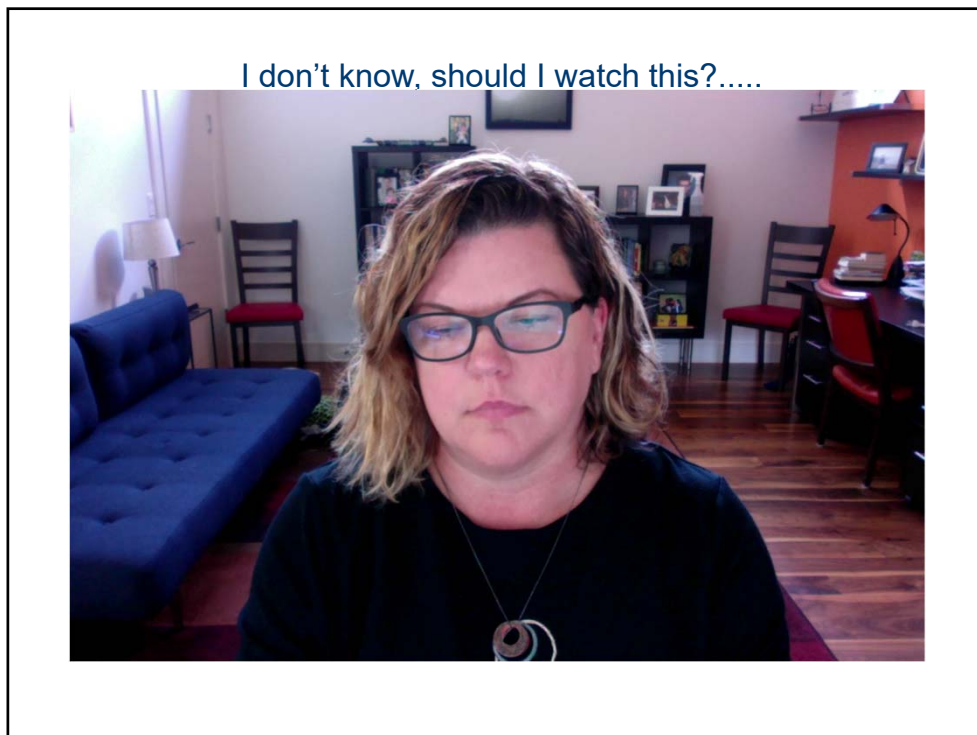
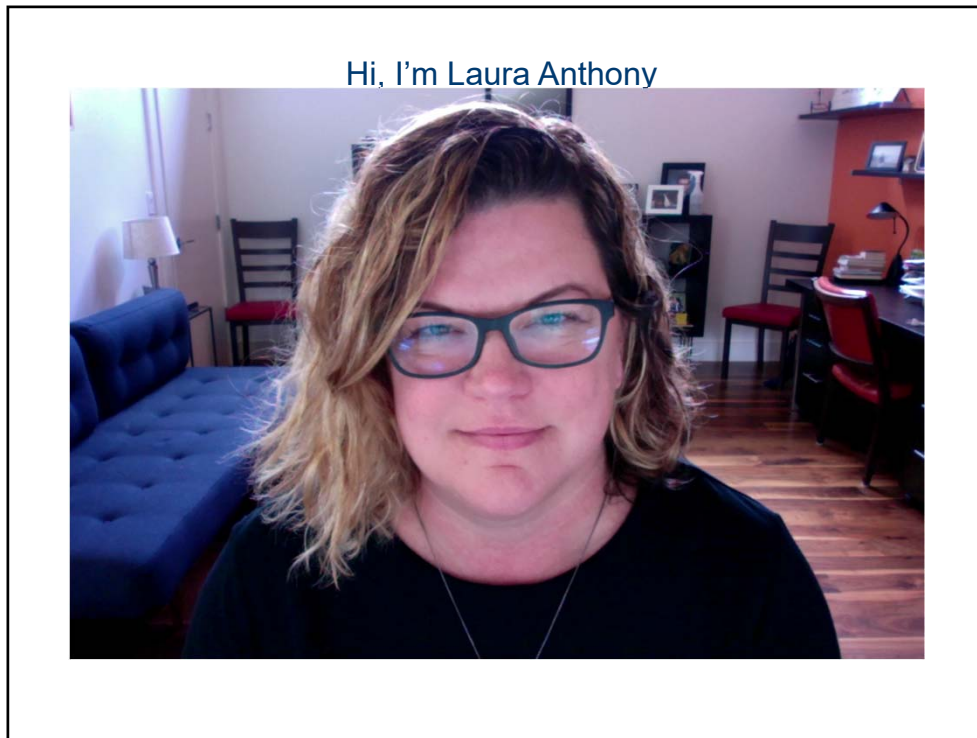

GOAL: Increase your understanding of how to identify and teach executive functioning skills and accommodate executive functioning weaknesses

PLAN:

1. Describe the importance of executive functioning (EF)
2. Describe the evidence we have that teaching EF skills works well for elementary-aged students
3. Teach flexibility, organization & planning skills using specific scripts or vocabulary and other tools



What we're going to be doing in Part 1



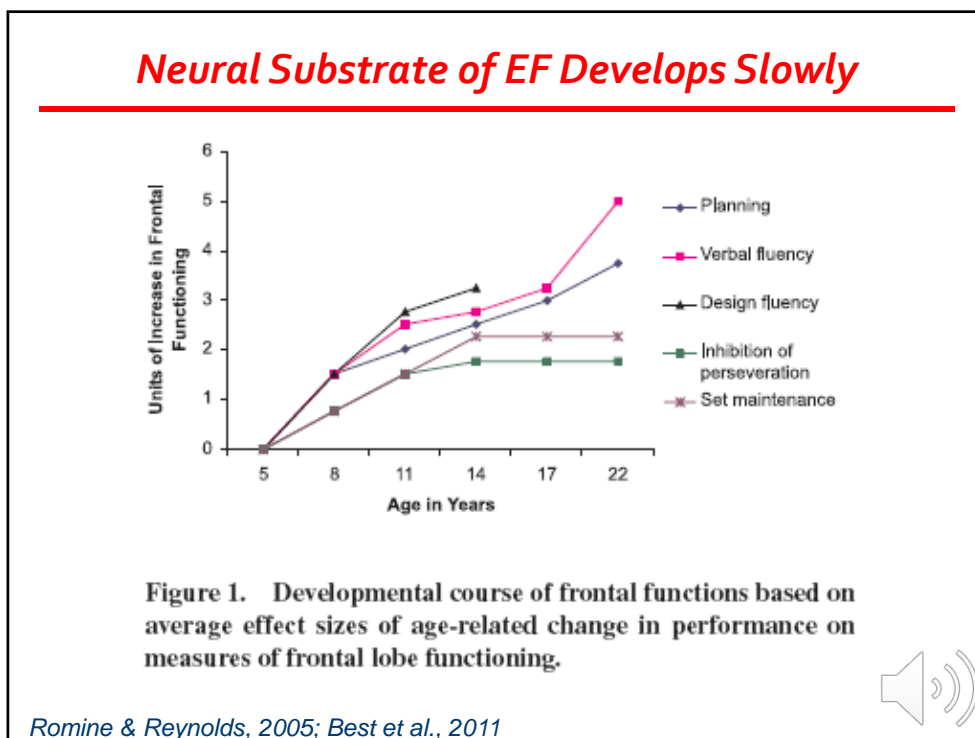
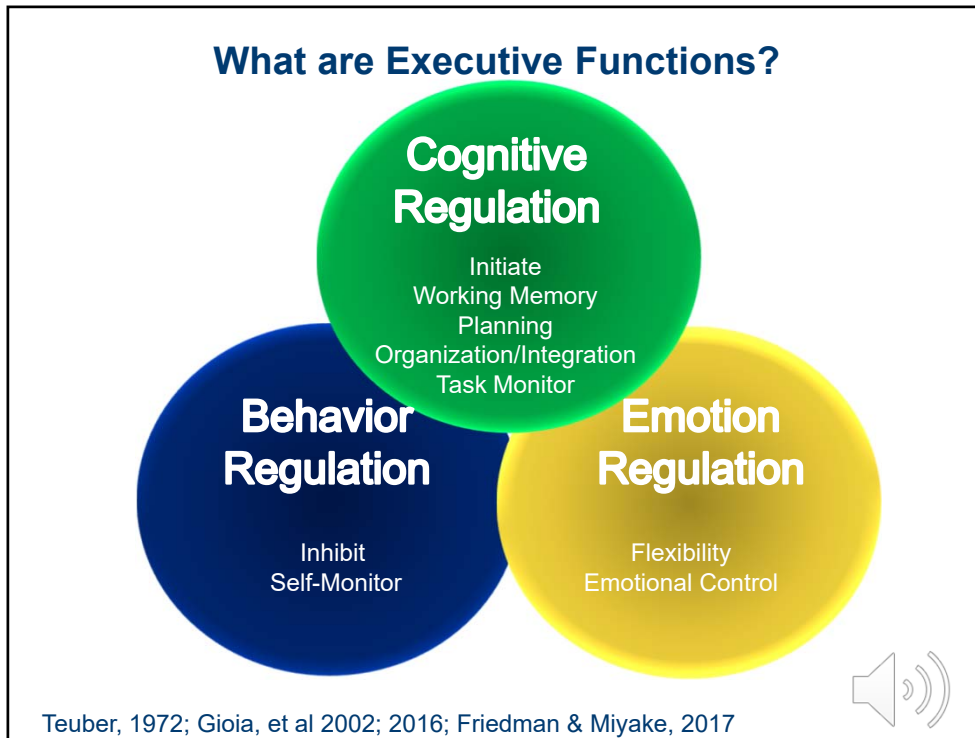

Neural Substrate of EF Develops Slowly

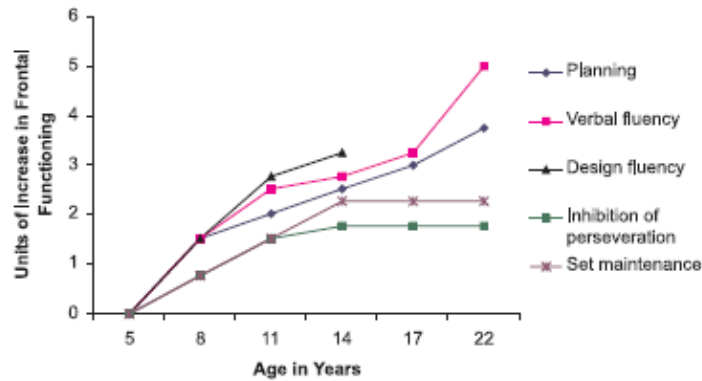
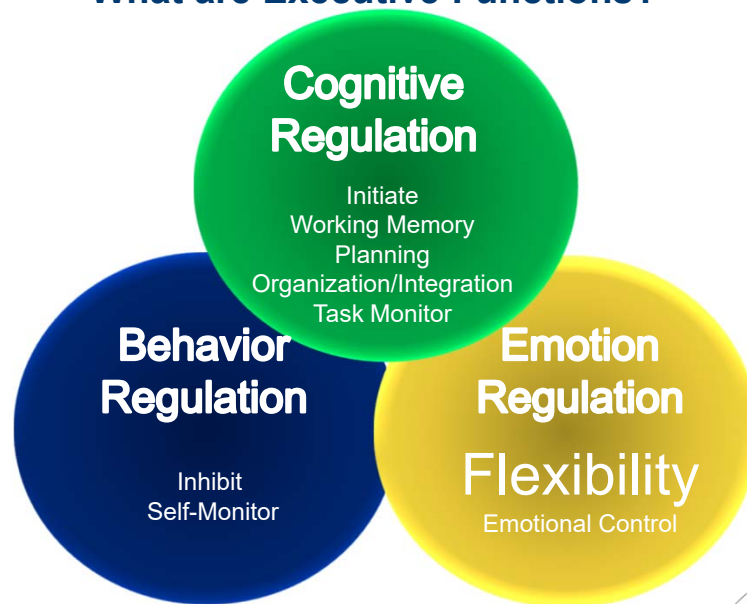

Figure 1. Developmental course of frontal functions based on average effect sizes of age-related change in performance on measures of frontal lobe functioning.

Romine & Reynolds, 2005; Best et al., 2011



What are Executive Functions?



Teuber, 1972; Gioia, et al 2002; 2016; Friedman & Miyake, 2017



**“Asperger’s is like a vise on your brain.
And each unexpected event is like
another turn on the vise...it just keeps
building until you feel like you’re going
to explode. Sometimes when you
explode, it comes out the wrong way.”
- A young student with ASD**

(Rumsey, 1985; Hill, 2004, Kenworthy et al, 2008)



What about you?

- How many of you have had an experience of having a vise on your brain?

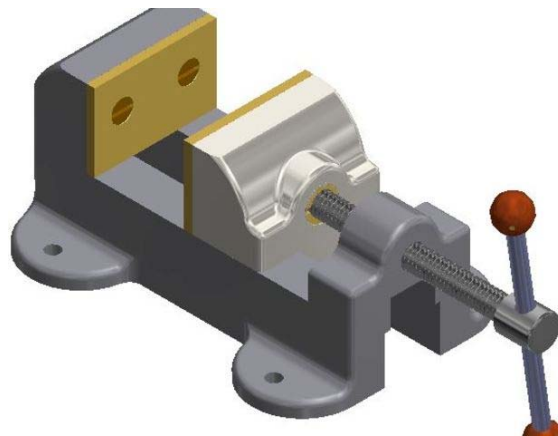

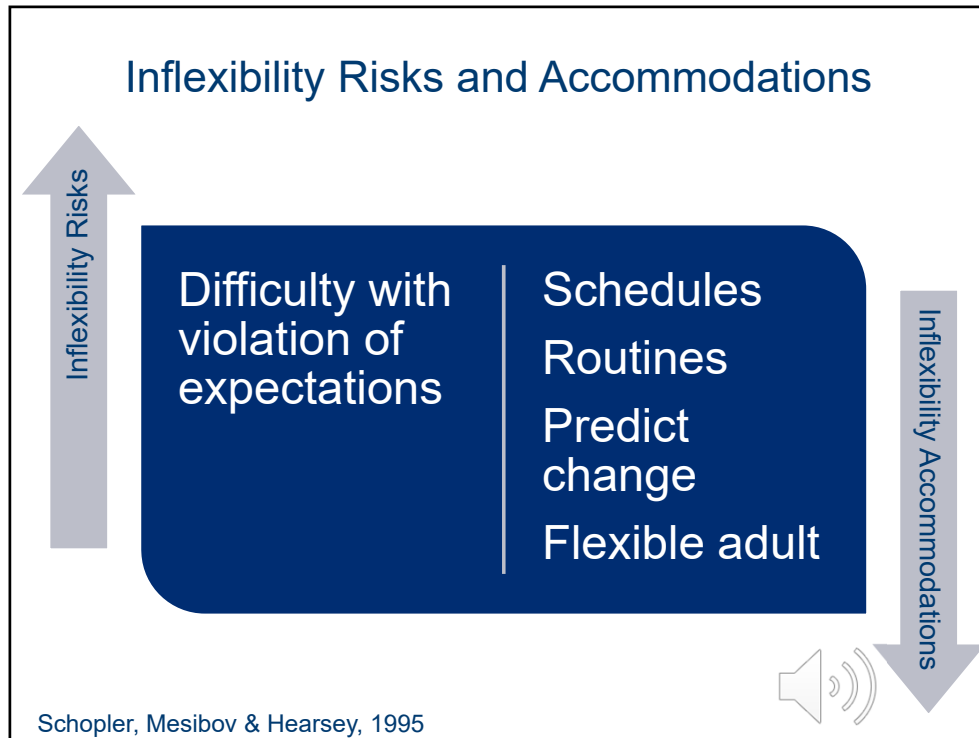

What about you?

- On a scale of 1 to 10, how hard is it for you to be flexible when a child has violated YOUR expectations?

1-10

This Photo by Unknown Author is licensed under [CC BY-SA](#)

14

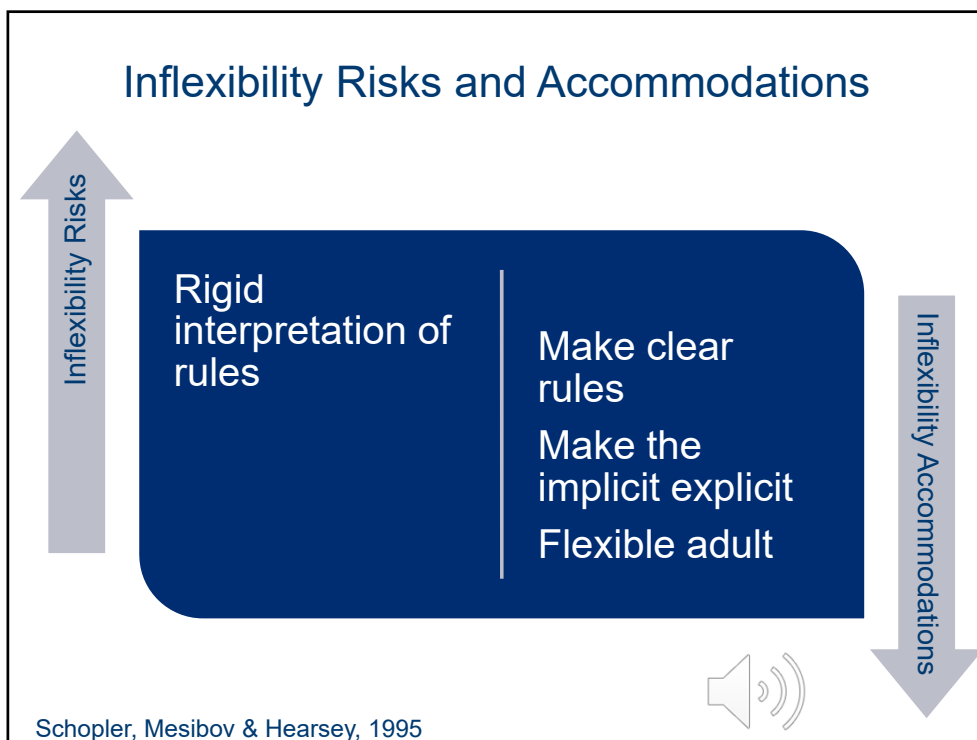

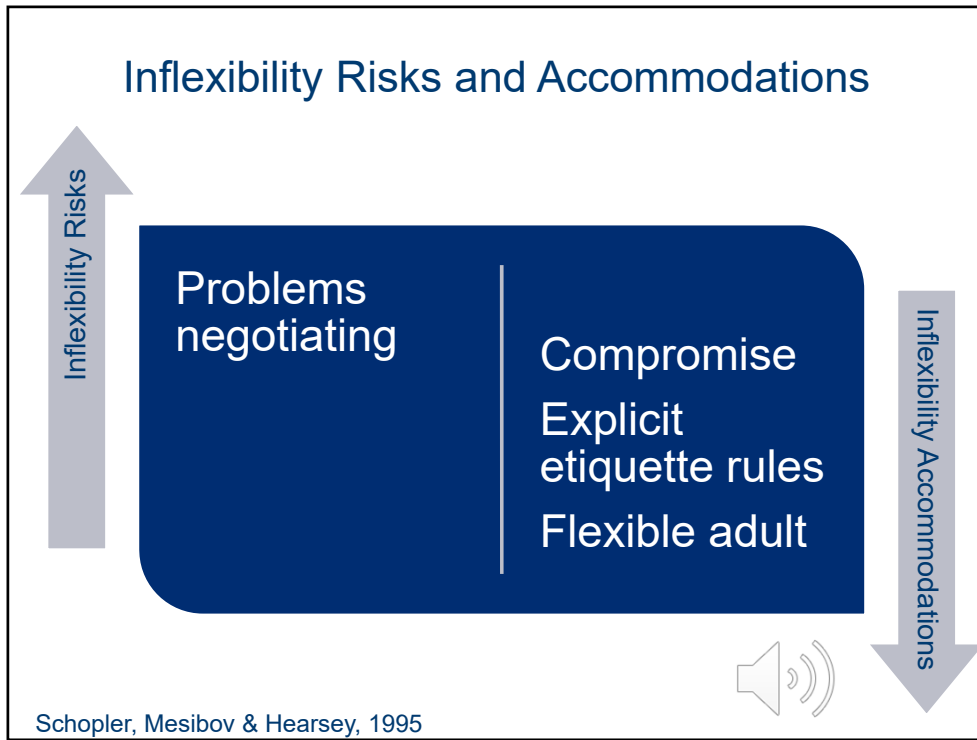

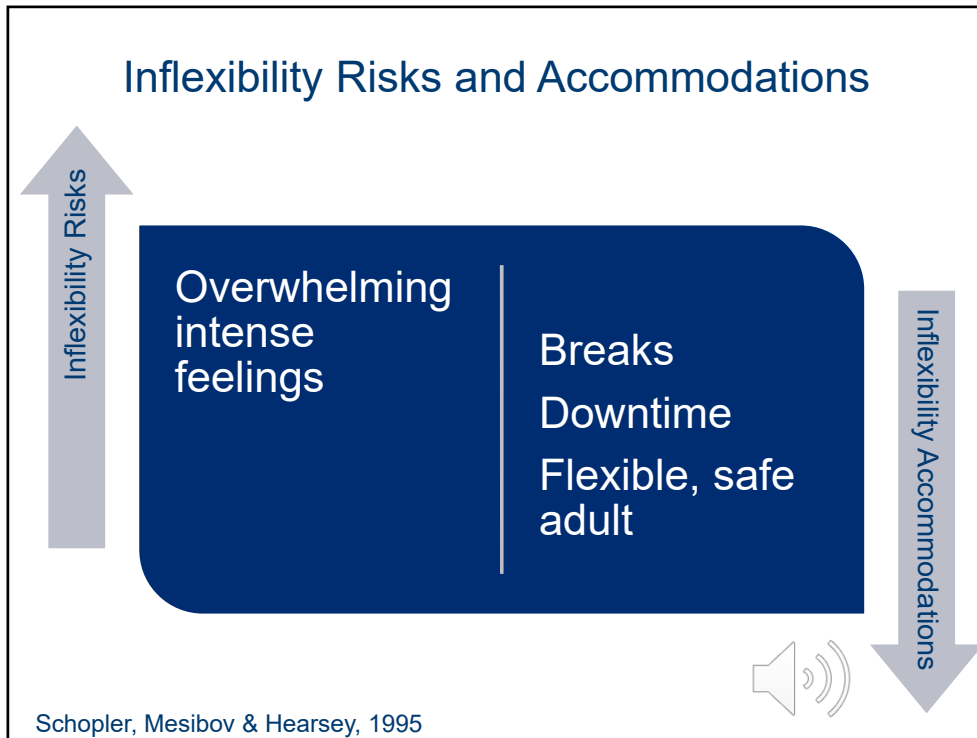

Inflexibility Strengths

- Deep datasets, expertise in areas of interest
- Persistence
- Reliability
- Loyalty
- Inflexibility is adaptive: It limits unexpected, overloading events
- Respect routines that don't interfere



Julia ©3CInstitute; unstuckontarget.com



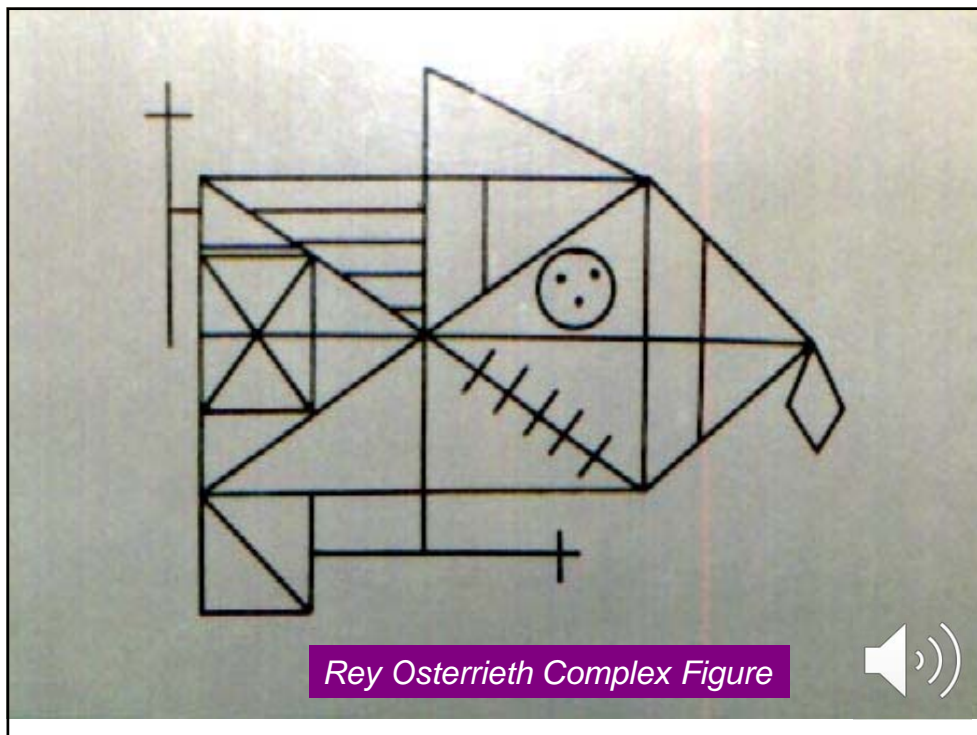
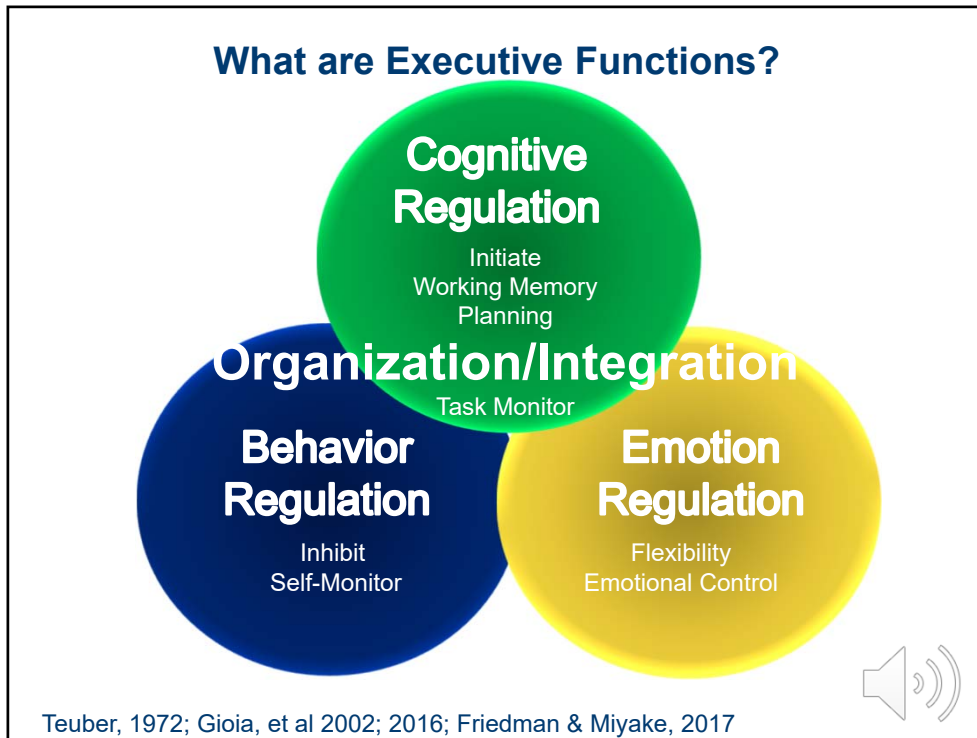

What about you? What would you start drawing first?

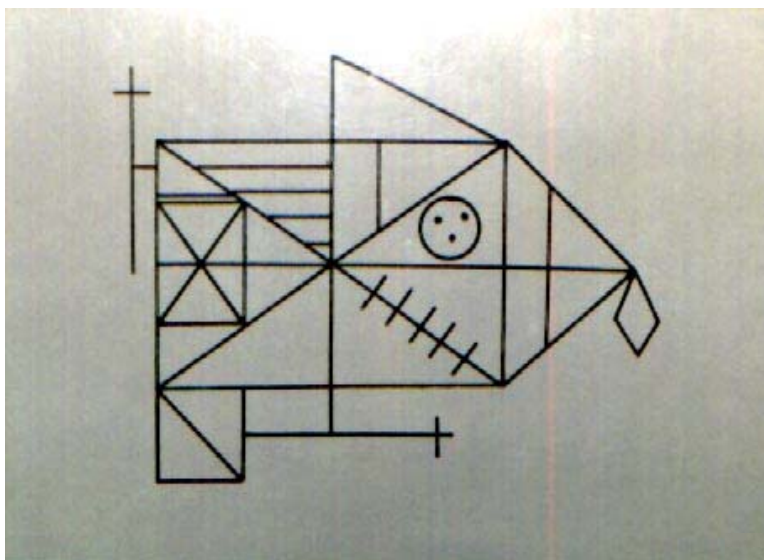

What about you? What would you start drawing first?

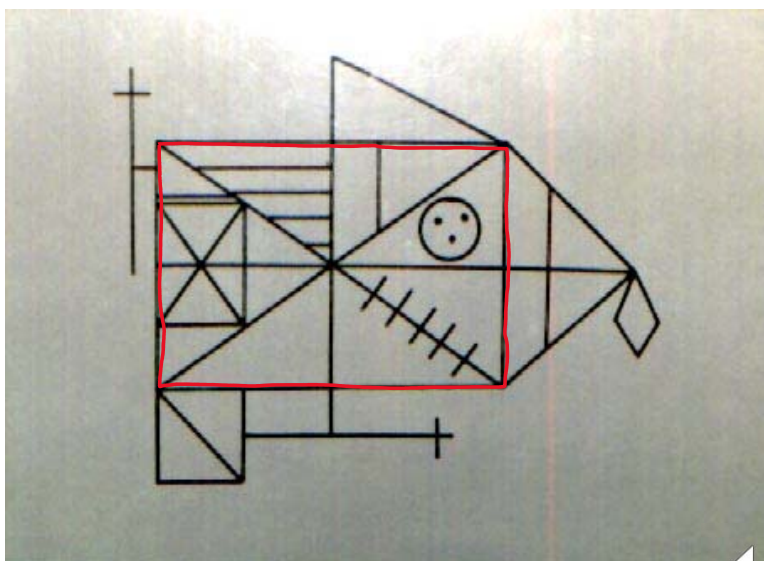

What about you? What would you start drawing first?

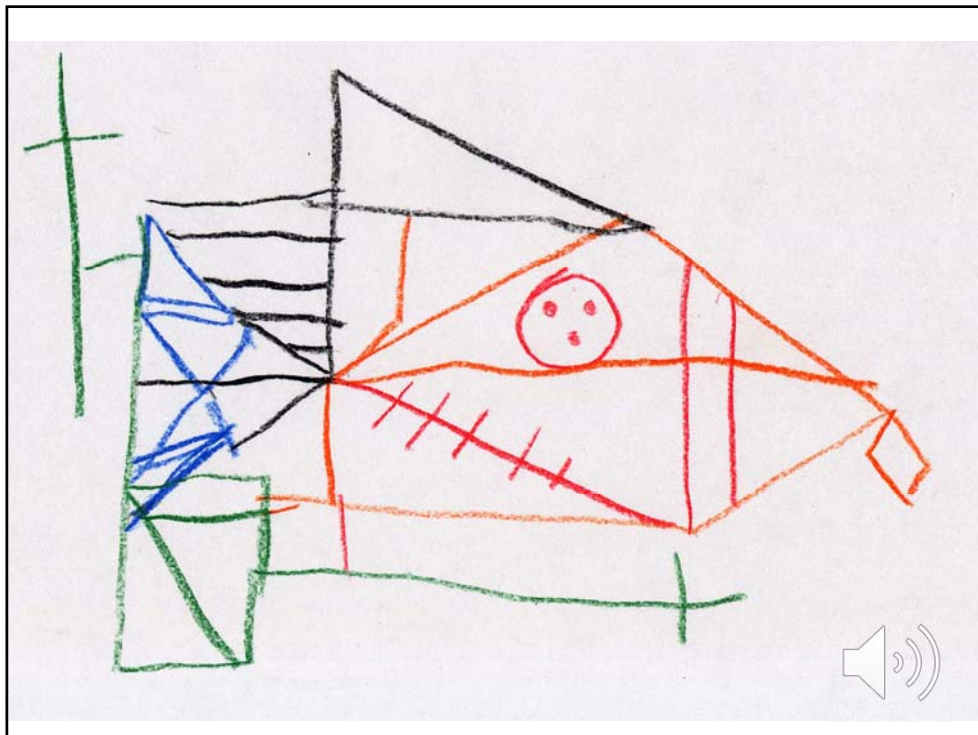
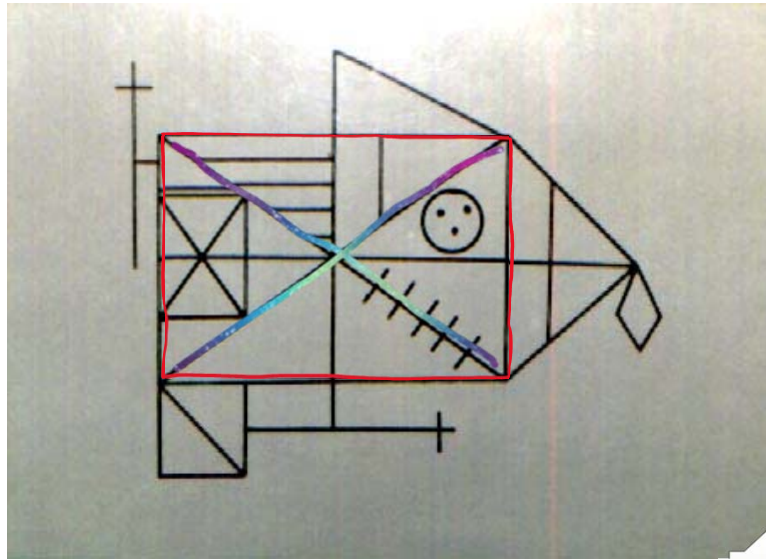

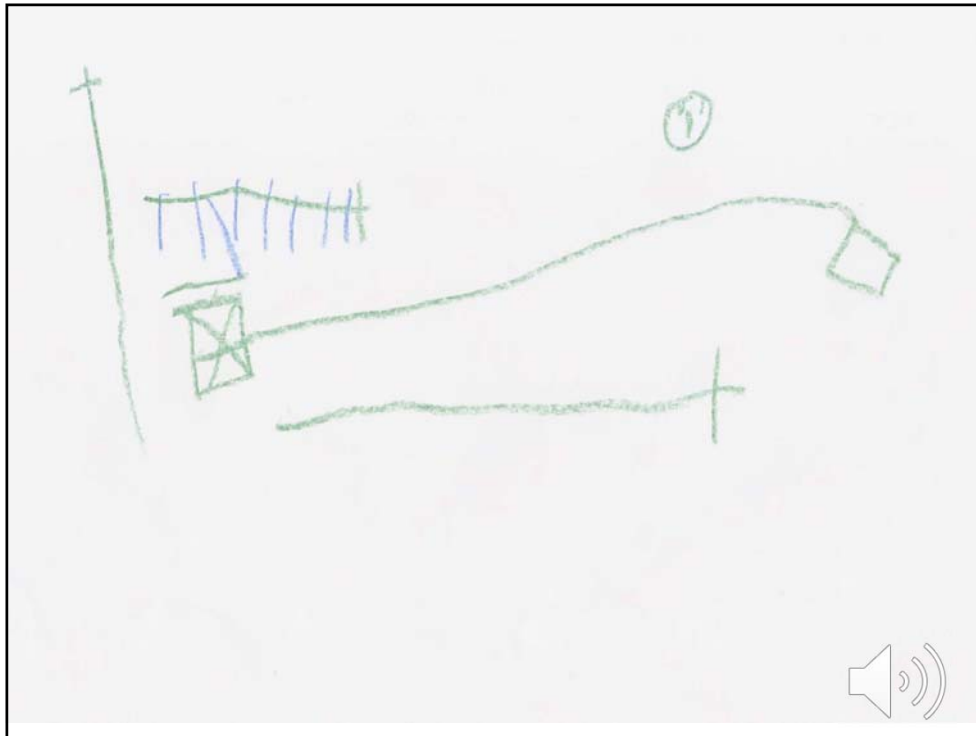

What about you?

Can't, or Won't?

1. Disorganized language
2. Literal language
3. Asks for lots of structure in new situations
4. Gets stuck on details- doesn't let go of small mistake or inconsistency
5. Dominates discussions without knowing it
6. Behaves worse in unstructured groups
7. Doesn't set goals
8. Trouble learning from mistakes
9. Poor written expression, Doesn't get good ideas onto paper
10. Trouble drawing meaning from a reading assignment
11. Not knowing what to study for on a test



What about you?

Can't, or Won't?

1. Disorganized language
2. Literal language
3. Asks for lots of structure in new situations
4. Gets stuck on details- doesn't let go of small mistake or inconsistency
5. Dominates discussions without knowing it
6. Behaves worse in unstructured groups
7. Doesn't set goals
8. Trouble learning from mistakes
9. Poor written expression, Doesn't get good ideas onto paper
10. Trouble drawing meaning from a reading assignment
11. Not knowing what to study for on a test



Disorganization Risks and Accommodations

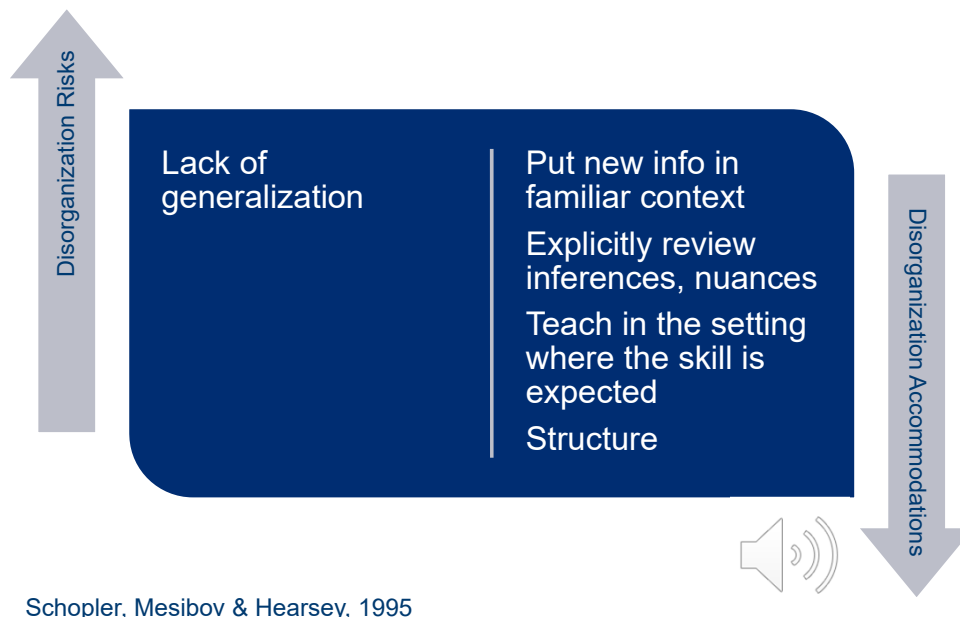

Schopler, Mesibov & Hearsey, 1995

Example of a generalization problem



This Photo by Unknown Author is licensed under [CC BY-NC-ND](#)



This Photo by Unknown Author is licensed under [CC BY-NC-ND](#)



Disorganization Risks and Accommodations

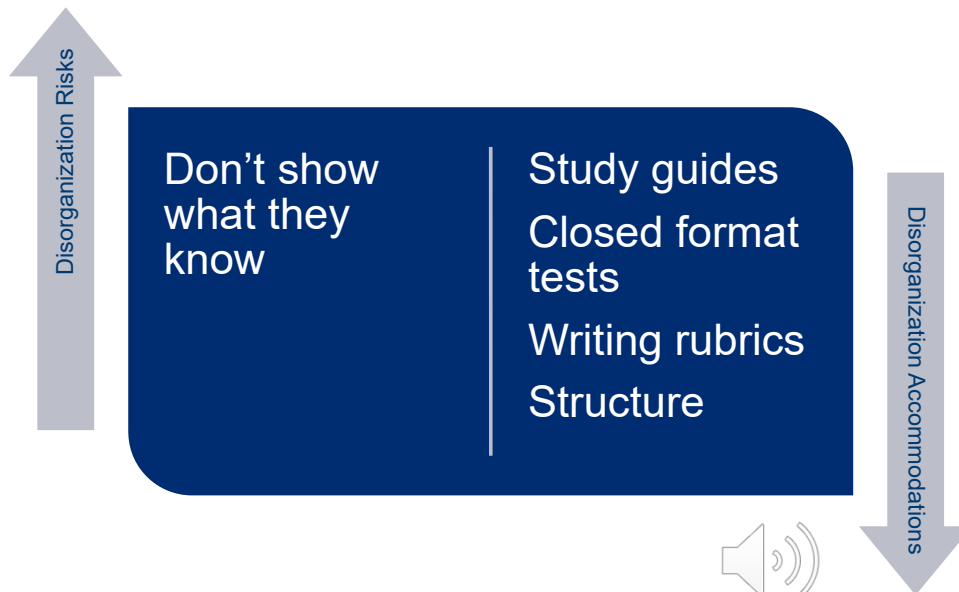

Schopler, Mesibov & Hearsey, 1995

Disorganization Risks and Accommodations

Disorganization Risks

Getting stuck on details

Or, difficulty knowing what is most important

Emphasis on goals

Break things down

Explicit short rules, checklists and routines

Structure

Disorganization Accommodations

Schopler, Mesibov & Hearsey, 1995

Disorganization Risks and Accommodations

Disorganization Risks

Getting stuck on details

Or, difficulty knowing what is most important

Emphasis on goals

Break things down

Explicit short rules, checklists and routines

Structure

Disorganization Accommodations

Schopler, Mesibov & Hearsey, 1995

Example of a Big Picture Problem



This Photo by Unknown Author is licensed under [CC BY-NC-ND](#)

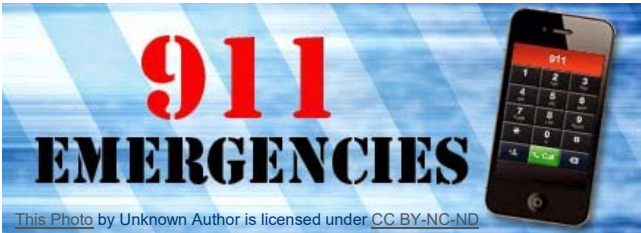

This Photo by Unknown Author is licensed under [CC BY-NC-ND](#)



Disorganization Risks and Accommodations



Disorganization Risks

Keeping track of so many details can lead to overload or what looks like a lack of awareness

Structure
Flexible, safe adult

Disorganization Accommodations



Schopler, Mesibov & Hearsey, 1995

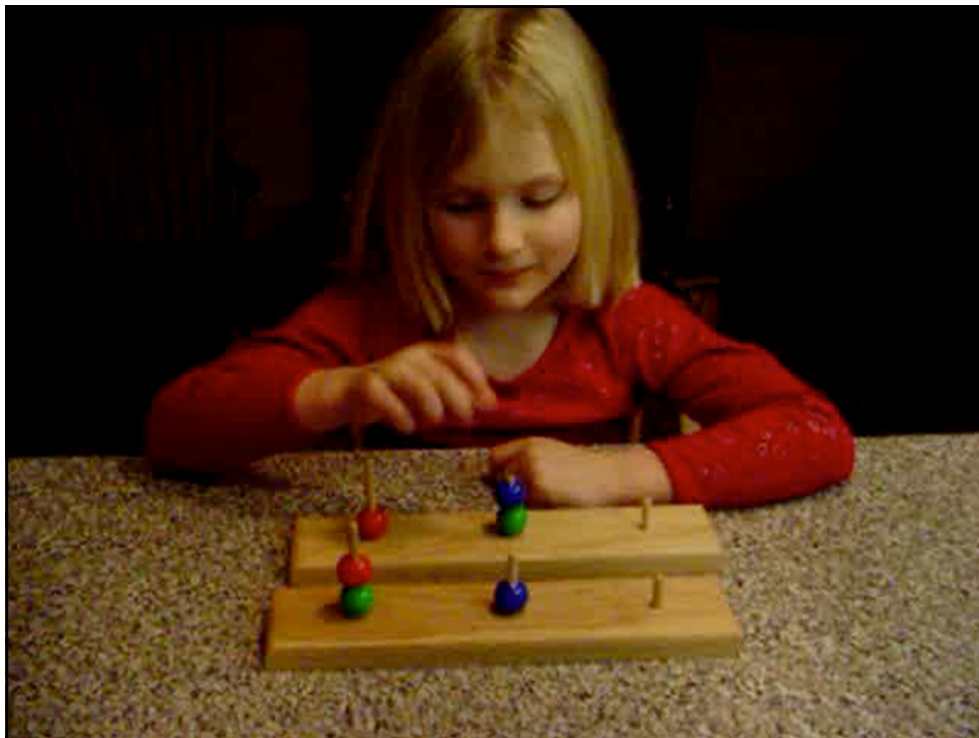
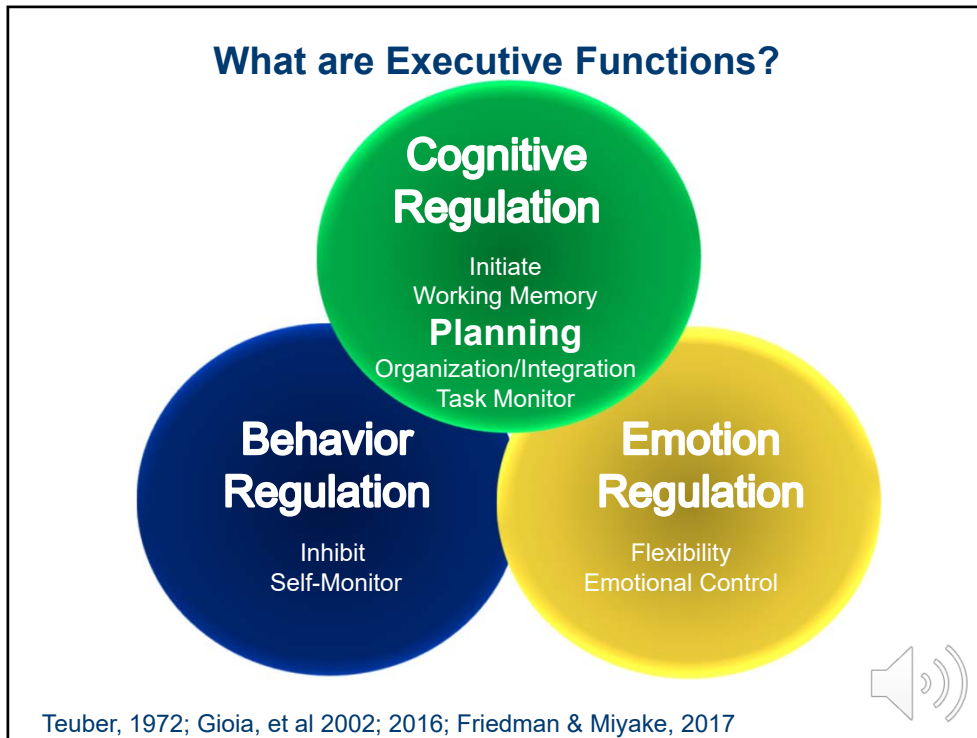

The Importance of Inner Speech

Social context

Language
↓
Self-directed speech
↓
Self-regulation
↓
Executive control
(Luria, 1961)



Lev Vygotsky
Thinking and Speech (1934)



Planning/Inner Speech/Working Memory Risks and Accommodations

Planning Risks ↑

Doesn't follow directions

Talk less, write more

Communicate via text/white board

Socratic method

↓ **Planning Accommodations**



Schopler, Mesibov & Hearsey, 1995

Planning/Inner Speech/Working Memory Risks and Accommodations

Doesn't follow directions	Talk less, write more Communicate via text/white board Socratic method
---------------------------	--

Schopler, Mesibov & Hearsey, 1995

Planning/Inner Speech/Working Memory Risks and Accommodations

Can't work independently	Use technology for tracking tasks, set reminders, instead of using a pencil Computer-based curricula
--------------------------	---

Schopler, Mesibov & Hearsey, 1995

The most important accommodations of them all:
Be Flexible and Keep it Positive!!

**Emotions are Contagious
...and Flexibility is too**

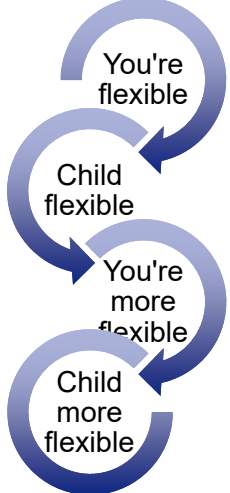

**Reinforcement Breaks a
Negative Cycle**

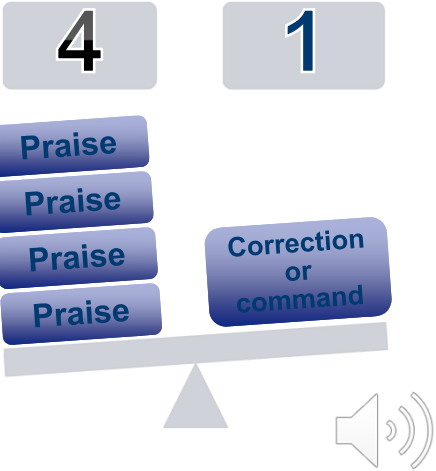

4

1

Praise

Praise

Praise

Praise

Correction or command

Coming up in future webinars

- How to tell if it's a can't or a won't
- How to explicitly teach EF skills
- How do we know that Unstuck and On Target works
- Additional resources
 - Online parent training program
 - What's next for Unstuck



46